

TAG: _____

SUBMITTAL

15 SERIES

Single Zone Mini-Split Inverter System

M4MHW2209A9N0A
M4THS2209A91NA

Specifications

MODEL - Heat Pump Only	M4MHW2209A / M4THS2209A	
	Cooling	Heating
RATED Volts/PH	115 / 1	
Frequency (Hz)	60Hz	
Rated Cooling / Heating Capacity (Btu/h):	9000	9500
Minimum Cooling Capacity (@95°F) (Btu/h):	2500	0
Maximum Cooling Capacity (@95°F) (Btu/h):	11600	0
Minimum Heating Capacity (@47°F) (Btu/h):	0	2400
Maximum Heating Capacity (@47°F) (Btu/h):	0	12900
Maximum Heating Capacity (@17°F) (Btu/h):	0	xxxx
Maximum Heating Capacity (@ 5°F) (Btu/h):	0	5700
Total Capacity (W) (High/Standard/Low):	3390 / 2610 / 750	3780 / 2760 / 690
Rated Power Input (W)	680	700
Nominal Input Current (A)	8.2	8.5
SEER / HSPF	22.0	9.8
Air Flow Volume (CFM) (H/M/L)	335 / 282 / 247 / 206	
Dehumidifying Volume (pt./h)	1.69	
EER / COP (@95°F)	13.2	13.6
Indoor Unit		
M4MHW2209A9N0		
Fan Motor Speed (r/min) (SH/H/M/L/Q)	1290/1100/950/750 1320/1200/1050/950	
Fan Motor RLA(A)	0.3	
Evaporator	Aluminum Fin-Copper Tube	
Pipe Diameter (inch)	0.28	
Row Fin Gap (inch)	2 - 1/16	
Coil length (L) x depth (D) x coil width (W) (inch)	25.4 x 1 x 10.5	
Output of Swing Motor (W)	2.0	
Fuse (A)	3.15	
Sound Power Level dB (A)(SH/H/M/L)	50 / 47 / 45 / 42	
Sound PRESSURE Level dB (A)(SH/H/M/L) ①	40 / 37 / 35 / 32	
Uncrated Dimension (W/H/D) (inch)	33.3 x 10.8 x 7.1	
Crated Dimension of Package (L/W/H) (inch)	36.1 x 10.2 x 14.6	
Net Weight /Gross Weight (lbs)	20.9 / 27.6	
Outdoor Unit		
M4THS2209A91N		
Compressor Type	Variable Speed Rotary	
Compressor Oil	RB68EP (POE Oil)	
Compressor RLA(A)	14.0	
Compressor Power Input(W)	942	
Throttling Method	EEV	
Working Temp Range (°F)	0 - 109	5 - 75
Condenser	Aluminum Fin-Copper Tube	
Pipe Diameter (inch)	Ø3/8	
Row Fin Gap (inch)	2 - 1/16	
Coil length (L) x depth (D) x coil width (W) (inch)	29.4 x 1.75 x 20	
Fan Motor Speed (rpm)	900	
Output of Fan Motor (W)	15	
Fan Motor RLA (A)	0.46	
Air Flow Volume of Outdoor Unit (CFM)	1060	
Fan Diameter (inch)	15.8	
Defrosting Method	Automatic Defrosting	
Sound Power Level dB (A)	62	
Sound PRESSURE Level dB (A) ①	52	
Uncrated Dimension (W/H/D) (inch)	33.4 x 21.3 x 12.6	
Crated Dimension of Package (L/W/H) (inch)	34.7 x 14.3 x 23.4	
Net Weight /Gross Weight (lbs)	73.9 / 82.7	
Refrigerant Charge (oz)	41.3	
MCA	20.0	
MOP	30.0	
Connection Pipe		
Gas additional charge(oz/ft)	0.2	
Outer Diameter Liquid Pipe (inch)	1/4	
Outer Diameter Gas Pipe (inch)	3/8	
Max Height Distance (ft)	33	
Max Length Distance (ft)	49	

① Sound PRESSURE Level @ 3.3 ft. dB(A)

Unit Dimensions

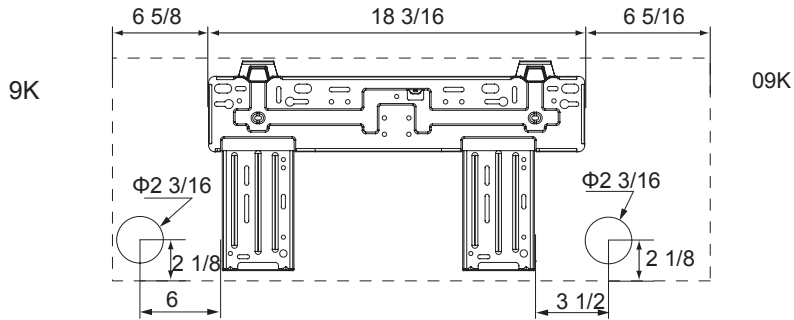
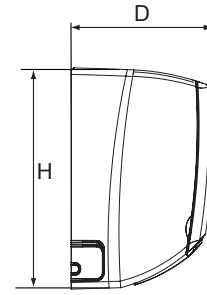
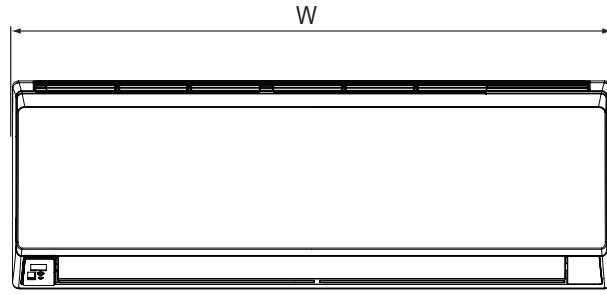

Unit: inch

MODEL	W	H	D
09K	$31 \frac{1}{9}$	$10 \frac{5}{6}$	$7 \frac{7}{8}$
12K	$33 \frac{1}{4}$	$11 \frac{3}{8}$	$8 \frac{2}{9}$

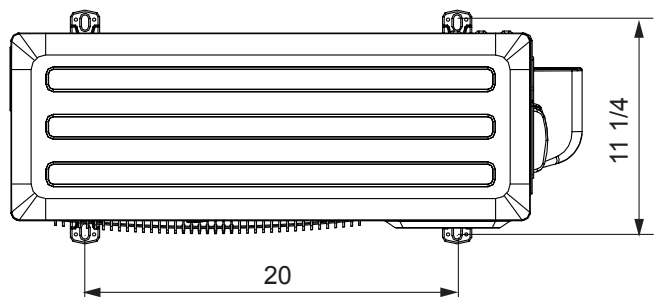
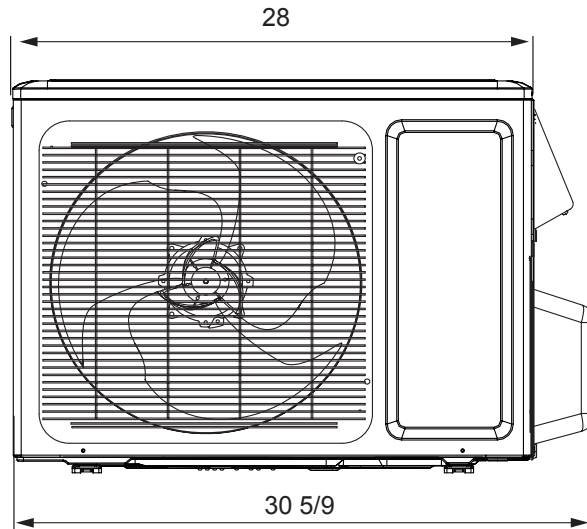
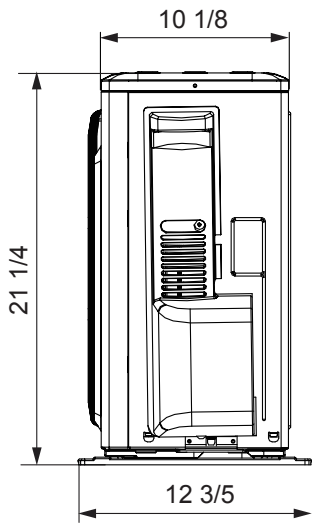

Clearance Requirements

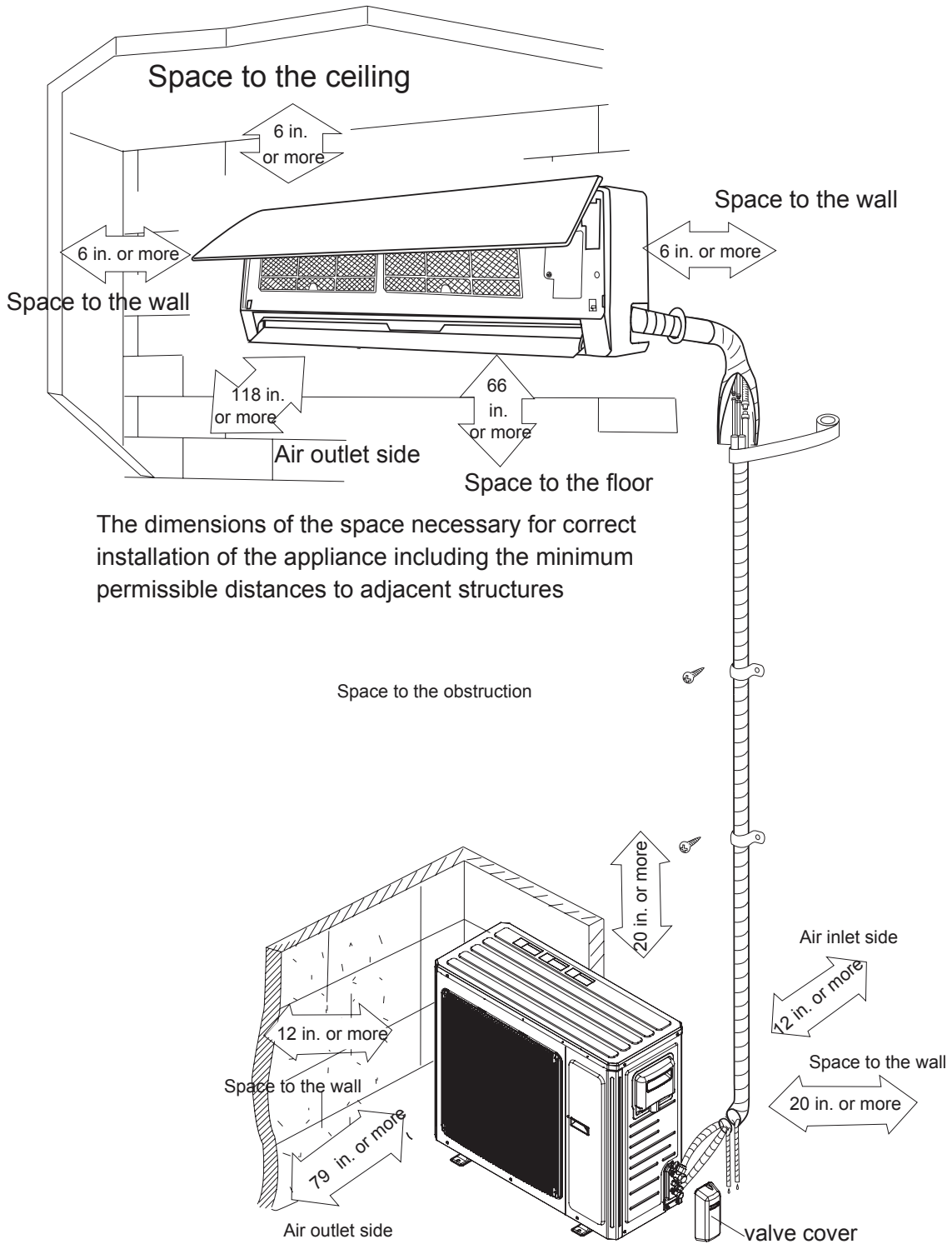

NOTE:

The maximum recommended height from the floor to the bottom of the indoor unit is 11.5 ft. (3.5 m).

Air Velocity Patterns for High Wall		
Max Horizontal Distance		
Unit: ft. (m)		
Model	Cooling Mode	Heating Mode
M4MHW2209A	13.1 (4)	13.1 (4)

Unit Capacities 9K Cooling

Cooling 9K

Outdoor		Indoor Coil Temperature																	
		65F DB (18C)		68F DB (20C)		73F DB (23C)		79F DB (26C)		80F DB (27C)		82F DB (28C)		86F DB (30C)		90F DB (32C)			
DB (°F)	DB (°C)	TC	SHC	TC	SHC	TC	SHC	TC	SHC	TC	SHC	TC	SHC	TC	SHC	TC	SHC		
0	-18	5100	4000	5600	4400	5900	4700	6400	5000	6700	5300	6800	5300	7000	5500	7600	6000		
5	-15	5200	4000	5800	4500	6100	4800	6500	5100	7100	5500	7100	5600	7300	5800	7900	6200		
10	-12	5500	4300	6000	4700	6400	5000	6800	5300	7400	5800	7500	5900	7700	6000	8200	6400		
15	-9	5900	4600	6300	4900	6800	5300	7200	5600	7800	6100	7900	6200	8200	6400	8600	6800		
20	-7	6600	5100	7100	5500	7500	5900	8000	6300	8500	6600	8600	6700	9100	7200	9600	7500		
25	-4	7200	5600	7700	6000	8200	6500	8700	6800	9100	7100	9200	7200	9900	7700	10500	8200		
30	-1	7700	6100	8300	6500	8800	6900	9200	7200	9600	7500	9700	7600	10300	8100	11000	8600		
35	2	7900	6200	8500	6600	9000	7000	9400	7300	9700	7600	9800	7700	10400	8200	11200	8800		
40	4	7900	6200	8400	6600	8900	7000	9300	7300	9700	7600	9800	7700	10400	8100	11100	8700		
45	7	7800	6100	8300	6500	8800	6900	9200	7200	9600	7500	9700	7600	10300	8100	11000	8600		
50	10	7700	6000	8200	6400	8700	6800	9100	7100	9600	7500	9700	7600	10200	8000	10900	8600		
55	13	7500	5900	8100	6300	8600	6700	9000	7100	9500	7400	9600	7500	10100	7900	10800	8500		
60	16	7400	5800	8000	6200	8500	6600	8900	7000	9400	7300	9500	7400	10100	7900	10700	8400		
65	18	7300	5700	7800	6100	8400	6600	8800	6900	9300	7300	9400	7300	10000	7800	10600	8300		
70	21	7200	5600	7700	6000	8300	6500	8700	6800	9200	7200	9300	7300	9900	7800	10500	8200		
75	24	7100	5500	7600	5900	8100	6400	8600	6800	9000	7100	9100	7100	9800	7700	10400	8100		
80	27	7000	5400	7500	5900	8000	6300	8500	6700	8900	7000	9000	7100	9700	7600	10200	8000		
85	29	6900	5400	7400	5800	7900	6200	8400	6600	8800	6900	8900	7000	9600	7500	10100	7900		
90	32	6800	5300	7300	5700	7800	6100	8300	6500	8800	6900	8900	7000	9500	7400	10000	7900		
95	35	6600	5200	7200	5600	7700	6000	8200	6400	8700	6800	8800	6900	9400	7400	9900	7800		
100	38	6500	5100	7100	5500	7600	6000	8100	6400	8600	6700	8700	6800	9300	7300	9800	7700		
105	41	6400	5000	7000	5500	7500	5900	8000	6300	8500	6700	8600	6700	9200	7200	9700	7600		
110	43	6300	5000	6900	5400	7400	5800	7900	6200	8400	6600	8500	6700	9100	7100	9600	7500		
115	46	6200	4900	6800	5300	7300	5700	7800	6100	8300	6500	8400	6600	9000	7000	9500	7400		
120	49	6100	4800	6700	5200	7100	5600	7700	6000	8100	6400	8200	6400	8800	6900	9300	7300		
122	50	6100	4800	6600	5200	7100	5500	7600	6000	8100	6300	8100	6400	8700	6800	9200	7200		

TC = Total Capacity

SHC = Sensible Heat Capacity

Unit Capacities 9K Heating

Heating 9K

Outdoor		Indoor Coil Temperature											
		65F DB (18C) 55F WB (13C)	68F DB (20C) 57F WB (14C)	73F DB (23C) 61F WB (16C)	79F DB (26C) 64F WB (18C)	80F DB (27C) 67F WB (19C)	82F DB (28C) 68F WB (20C)	86F DB (30C) 72F WB (22C)					
DB (°F)	DB (°C)	TC	TC	TC	TC	TC	TC	TC	TC	TC	TC	TC	TC
-4	-20	5100	4900	4900	4800	4800	4700	4600					
0	-18	5500	5400	5300	5200	5200	5100	5000					
5	-15	5800	5600	5500	5500	5500	5300	5200					
10	-12	6100	5900	5800	5800	5700	5600	5500					
15	-9	6200	6000	6000	5900	5900	5800	5600					
20	-7	6500	6300	6300	6100	6200	6000	5900					
25	-4	7200	7000	6900	6800	6800	6700	6600					
30	-1	7700	7500	7400	7300	7300	7200	7100					
35	2	8200	8000	7900	7800	7800	7700	7600					
40	4	8700	8500	8400	8300	8300	8200	8100					
45	7	9500	9200	9200	9000	9000	8900	8700					
50	10	10000	9700	9600	9500	9400	9200	9000					
55	13	10100	9800	9700	9600	9500	9400	9100					
60	16	10300	10000	9900	9800	9700	9500	9300					
65	18	10500	10200	10100	10000	9900	9700	9500					
70	21	10700	10400	10300	10200	10100	9900	9600					
75	24	10800	10500	10400	10300	10200	10000	9800					
78	26	10900	10600	10500	10400	10300	10100	9900					

TC = Total Capacity

Mechanical Specifications

Mini-Split Outdoor Unit

General

This unit is fully charged from the factory for up to 25 feet of piping. This unit is designed to operate at outdoor ambient temperatures as high as 115°F. Cooling capacities with the mini-split air handler shown in the catalog are AHRI certified. The unit is ETL listed for outdoor application.

Unit Casing

The unit casing is constructed of heavy gauge, galvanized steel and painted with a weather-resistant powder paint.

Refrigerant Controls

Refrigeration system controls include condenser fan and compressor relay. High and low pressure controls are inherent to the compressor. A suction line multi function service valve is standard

Compressor

The compressor features internal over temperature and pressure protection; total dipped hermetic motor windings. Other features include: centrifugal oil pump and low vibration and noise.

Condenser Coil

The coil shall consist of aluminum finned coils brazed to copper tubing. The coil provides air flow resistance and efficient heat transfer. The coil is protected by the casing.

Low Ambient Cooling

Matched Ameristar ductless products, have cooling capabilities at outdoor ambient temperatures as low as 0° F.

Mini-Split Indoor High Wall

General

The High Wall mounted type air handler shall be completely factory assembled including coil, condensate drain pan, fan motor, washable filter, air purifying filter and electric controls to be used with a wireless remote controller. Unit shall be shipped with a unit mounting plate. Unit shall be matched with an Ameristar outdoor unit, rated and tested in accordance with AHRI standard. Unit shall be ETL listed.

Unit Casing

Casing shall be provided with knockouts on the right, and left of the unit to facilitate piping and electrical connection on either side of the unit. An electrical service cover shall be provided to permit easy access to the electrical terminal strip.

Discharge Airflow and Distribution System

Unit shall have auto swing, dual horizontal blades to optimize the aperture outlet for vertical airflow and air distribution. Blade shall close automatically when the air conditioner is turned off to minimize dust entering the unit. Five-Step preset program on the remote controller shall be available to control the blade angle.

Manually adjusted wide-angle louvers shall be provided to adjust the coverage and direction of airflow.

Controls

Units shall have the capability to be controlled remotely through wall-mounted wired options as well as a wireless remote option.

Remote Controller

The unit shall have a wireless infrared remote controller with easy reading digital display panel to start, stop and regulate the air conditioner from a distance.

The wireless controller is available for all units. **(Sold separately)**

Healthy Filters

The unit shall have an active carbon and catechin filter with the unit. The filters need to be cleaned at least once a year.



TAG: _____

SUBMITTAL

22 SERIES

Single Zone Mini-Split Inverter System

M4MHW2212A9N0A

M4THS2212A91NA

Specifications

MODEL - Heat Pump Only	M4MHW2212A9 / M4THS2212A9	
	Cooling	Heating
RATED Volts/PH	115 / 1	
Frequency (Hz)	60Hz	
Rated Cooling / Heating Capacity (Btu/h):	12000	13000
Minimum Cooling Capacity (@95°F) (Btu/h):	2600	0
Maximum Cooling Capacity (@95°F) (Btu/h):	13300	0
Minimum Heating Capacity (@47°F) (Btu/h):	0	2900
Maximum Heating Capacity (@47°F) (Btu/h):	0	13900
Maximum Heating Capacity (@17°F) (Btu/h):	0	xxxx
Maximum Heating Capacity (@ 5°F) (Btu/h):	0	7700
Total Capacity (W) (High/Standard/Low):	3900 / 3510 / 780	4080 / 3810 / 840
Rated Power Input (W)	1000	1200
Nominal Input Current (A)	12.0	14.5
SEER / HSPF	20.0	9.6
Air Flow Volume (CFM) (H/M/L)	335 / 282 / 247 / 206	
Dehumidifying Volume (pt./h)	2.96	
EER / COP (@95°F)	12.0	10.8
Indoor Unit		
M4MHW2212A9N0		
Fan Motor Speed (r/min) (SH/H/M/L/Q)	1290/1100/950/750	1320/1200/1050/950
Fan Motor RLA(A)	0.3	
Evaporator	Aluminum Fin-Copper Tube	
Pipe Diameter (inch)	0.28	
Row Fin Gap (inch)	2 - 1/16	
Coil length (L) x depth (D) x coil width (W) (inch)	25.4 x 1 x 10.5	
Output of Swing Motor (W)	2.0	
Fuse (A)	3.15	
Sound Power Level dB (A)(SH/H/M/L)	52 / 49 / 46 / 43	
Sound PRESSURE Level dB (A)(SH/H/M/L) ①	42 / 39 / 36 / 33	
Uncrated Dimension (W/H/D) (inch)	33.3 x 10.8 x 7.1	
Crated Dimension of Package (L/W/H) (inch)	36.1 x 10.2 x 14.6	
Net Weight /Gross Weight (lbs)	20.9 / 27.6	
Outdoor Unit		
M4THS2212A91N		
Compressor Type	Variable Speed Rotary	
Compressor Oil	RB68EP (POE Oil)	
Compressor RLA(A)	15.0	
Compressor Power Input(W)	942	
Throttling Method	EEV	
Working Temp Range (°F)	0 - 109	5 - 75
Condenser	Aluminum Fin-Copper Tube	
Pipe Diameter (inch)	Ø3/8	
Row Fin Gap (inch)	2 - 1/16	
Coil length (L) x depth (D) x coil width (W) (inch)	29.4 x 1.75 x 22	
Fan Motor Speed (rpm)	900	
Output of Fan Motor (W)	15	
Fan Motor RLA (A)	0.46	
Air Flow Volume of Outdoor Unit (CFM)	1177	
Fan Diameter (inch)	15.8	
Defrosting Method	Automatic Defrosting	
Sound Power Level dB (A)	62	
Sound PRESSURE Level dB (A) ①	52	
Uncrated Dimension (W/H/D) (inch)	33.4 x 23.3 x 12.6	
Crated Dimension of Package (L/W/H) (inch)	34.7 x 14.3 x 25.4	
Net Weight /Gross Weight (lbs)	76.1 / 84.9	
Refrigerant Charge (oz)	45.9	
MCA	20.0	
MOP	30.0	
Connection Pipe		
Gas additional charge(oz/ft)	0.2	
Outer Diameter Liquid Pipe (inch)	1/4	
Outer Diameter Gas Pipe (inch)	3/8	
Max Height Distance (ft)	33	
Max Length Distance (ft)	66	

① Sound PRESSURE Level @ 3.3 ft. dB(A)

Unit Dimensions

Indoor Unit

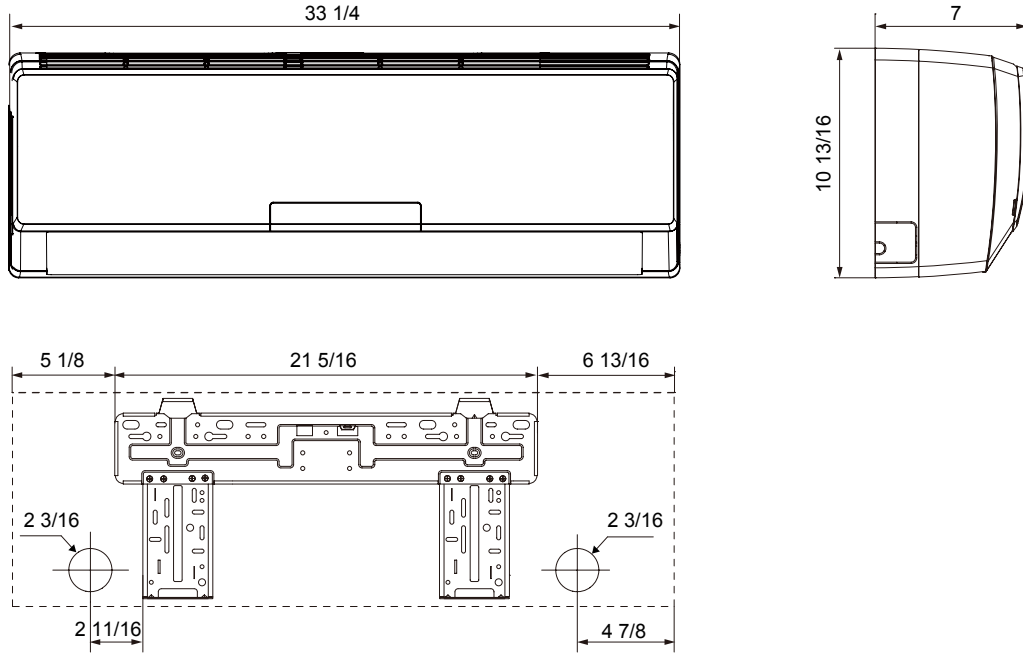

Unit: inch

Outdoor Unit

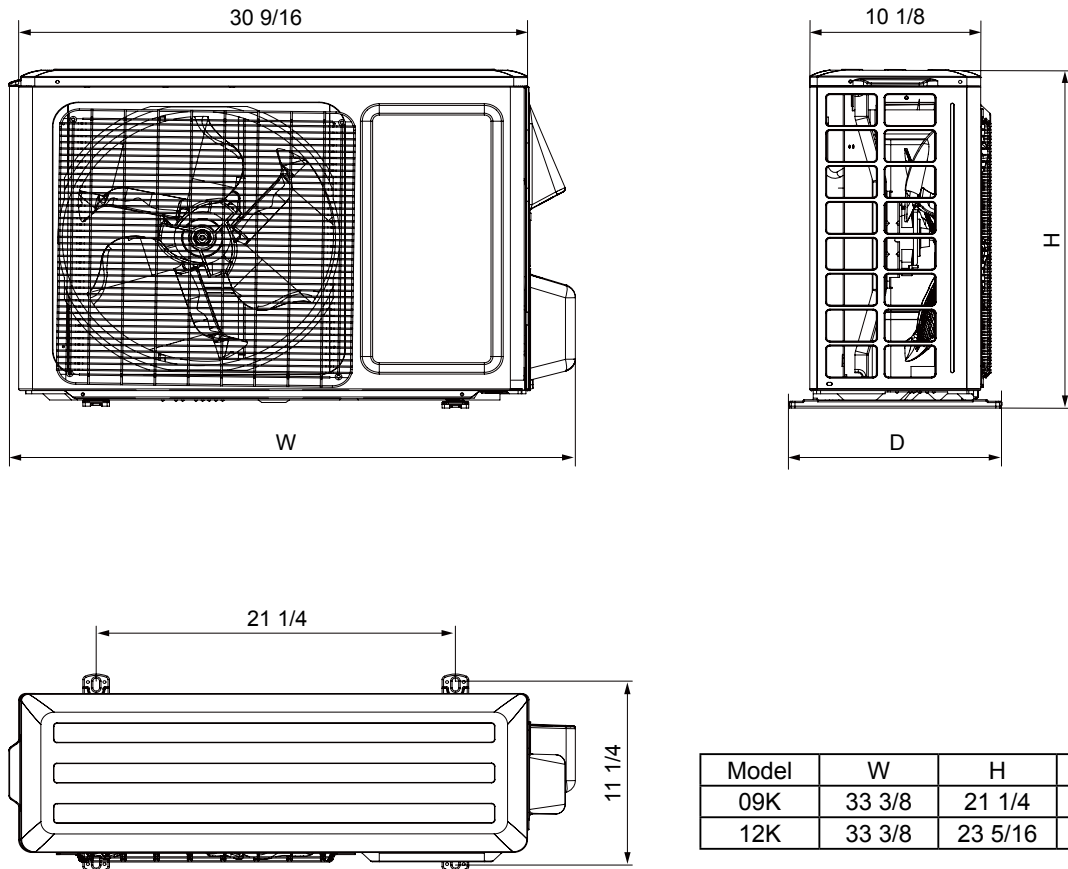

Unit: inch

Model	W	H	D
09K	$33 \frac{3}{8}$	$21 \frac{1}{4}$	$12 \frac{5}{8}$
12K	$33 \frac{3}{8}$	$23 \frac{5}{16}$	$12 \frac{5}{8}$

Clearance Requirements

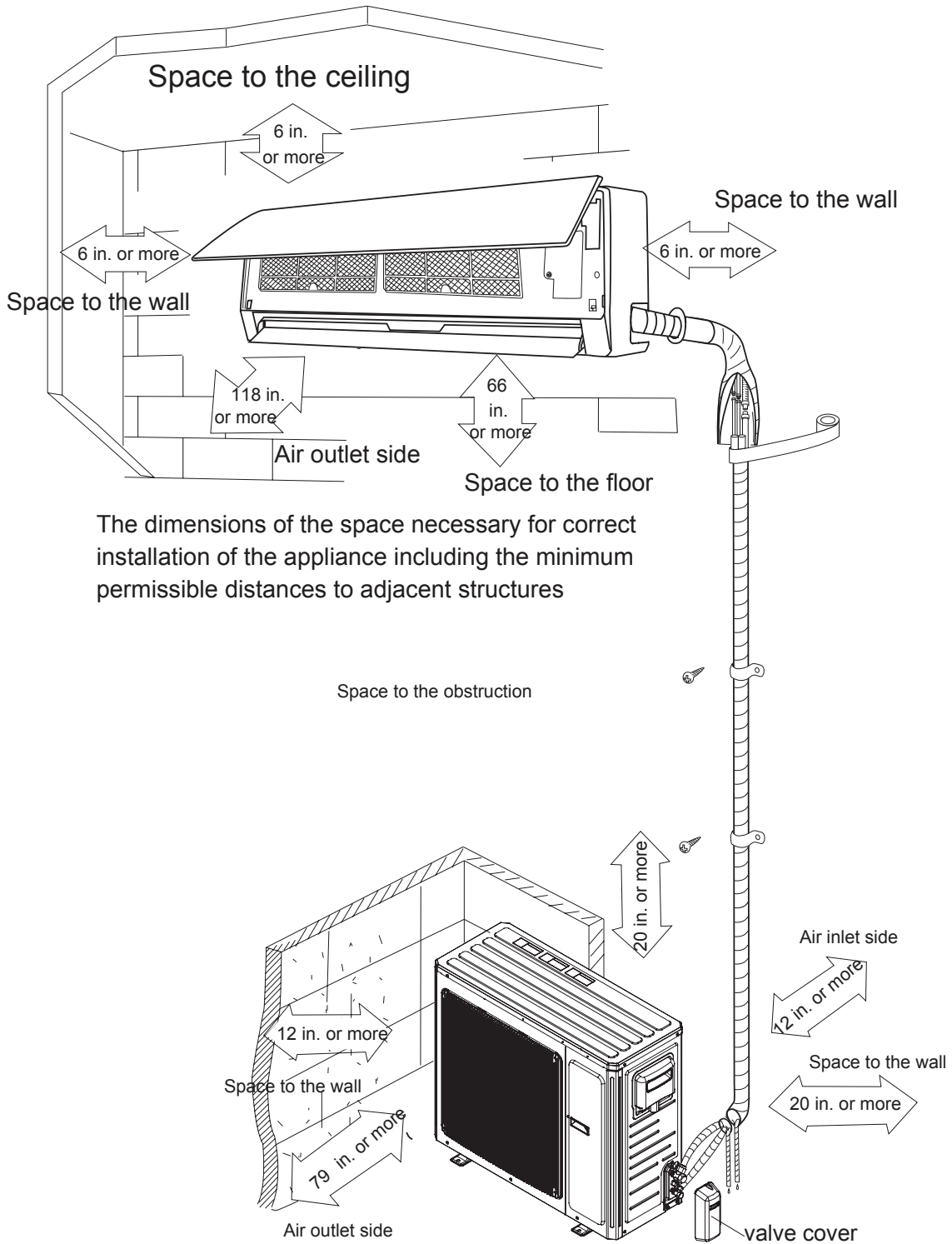

NOTE:

The maximum recommended height from the floor to the bottom of the indoor unit is 11.5 ft. (3.5 m).

Air Velocity Patterns for High Wall		
Max Horizontal Distance		
Unit: ft. (m)		
Model	Cooling Mode	Heating Mode
M4MHW2212A9	29.5 (9)	19.7 (6)

Unit Capacities 12K Cooling

Cooling 12K

Outdoor		Indoor Coil Temperature																	
		65F DB (18C)		68F DB (20C)		73F DB (23C)		79F DB (26C)		80F DB (27C)		82F DB (28C)		86F DB (30C)		90F DB (32C)			
DB (°F)	DB (°C)	55F WB (13C)		57F WB (14C)		61F WB (16C)		64F WB (18C)		67F WB (19C)		68F WB (20C)		72F WB (22C)		75F WB (24C)			
		TC	SHC	TC	SHC	TC	SHC	TC	SHC	TC	SHC	TC	SHC	TC	SHC	TC	SHC		
0	-18	5900	4600	6500	5100	6800	5300	7300	5700	7700	6000	7800	6100	8000	6300	8700	6800		
5	-15	6200	4800	6800	5300	7200	5600	7700	6000	8100	6300	8200	6500	8400	6600	9000	7100		
10	-12	6600	5200	7200	5700	7600	6000	8200	6400	8600	6800	8800	6900	9000	7000	9700	7600		
15	-9	7000	5500	7700	6000	8100	6400	8700	6800	9200	7200	9400	7300	9600	7500	10400	8100		
20	-7	7500	5900	8100	6300	8600	6800	9200	7200	9800	7700	10000	7800	10300	8000	10900	8600		
25	-4	7800	6100	8400	6600	9000	7100	9600	7500	10300	8100	10500	8200	10800	8500	11400	8900		
30	-1	8100	6300	8700	6800	9300	7300	9900	7700	10600	8300	10800	8500	11100	8700	11700	9200		
35	2	8300	6500	8900	7000	9500	7500	10200	8000	10900	8600	11100	8700	11400	8900	12000	9400		
40	4	8500	6700	9200	7200	9800	7700	10400	8200	11200	8800	11400	9000	11700	9200	12400	9700		
45	7	8800	6900	9400	7400	10100	7900	10700	8400	11500	9000	11700	9200	12000	9400	12700	10000		
50	10	9000	7000	9700	7600	10300	8100	11000	8600	11900	9300	12000	9400	12400	9700	13000	10200		
55	13	9200	7200	9900	7800	10600	8300	11300	8900	11900	9300	12000	9400	12700	9900	13400	10500		
60	16	9600	7500	10300	8000	11000	8600	11700	9100	12000	9400	12200	9600	13100	10200	13800	10800		
65	18	10300	8100	11000	8600	11700	9200	12300	9600	12600	9900	12900	10100	13600	10700	14500	11400		
70	21	10700	8400	11400	9000	12200	9500	12600	9900	13000	10200	13200	10400	14000	10900	14900	11700		
75	24	10600	8300	11400	8900	12100	9500	12600	9900	12900	10100	13200	10300	13900	10900	14900	11600		
80	27	10400	8200	11100	8700	11900	9300	12400	9700	12800	10000	13000	10200	13700	10700	14700	11500		
85	29	10100	7900	10800	8500	11600	9100	12100	9500	12600	9900	12800	10000	13500	10600	14400	11300		
90	32	9800	7700	10500	8200	11200	8800	11900	9300	12300	9600	12500	9800	13300	10400	14100	11000		
95	35	9500	7400	10200	8000	10900	8500	11600	9100	12000	9400	12200	9500	13100	10200	13800	10800		
100	38	9200	7200	9900	7800	10600	8300	11300	8900	11800	9200	12000	9400	12800	10000	13500	10600		
105	41	8900	7000	9600	7600	10400	8100	11100	8700	11600	9100	11800	9200	12500	9800	13200	10300		
110	43	8600	6800	9400	7300	10100	7900	10800	8500	11300	8900	11500	9000	12200	9600	12900	10100		
115	46	8400	6600	9100	7200	9800	7700	10500	8300	11100	8700	11200	8800	12000	9400	12700	9900		
120	49	8300	6500	9000	7100	9600	7500	10300	8100	10800	8500	11000	8600	11700	9200	12400	9700		
122	50	8200	6400	9000	7000	9600	7500	10300	8000	10800	8400	10900	8600	11700	9100	12300	9600		

TC = Total Capacity

SHC = Sensible Heat Capacity

Unit Capacities 12K Heating

Heating 12K

		Indoor Coil Temperature											
Outdoor		65F DB (18C)	68F DB (20C)	73F DB (23C)	79F DB (26C)	80F DB (27C)	82F DB (28C)	86F DB (30C)					86F DB (30C)
Coil air		55F WB (13C)	57F WB (14C)	61F WB (16C)	64F WB (18C)	67F WB (19C)	68F WB (20C)	72F WB (22C)					72F WB (22C)
DB (°F)	DB (°C)	TC	TC	TC	TC	TC	TC	TC	TC	TC	TC	TC	TC
-4	-20	6800	6700	6600	6800	6800	6900	6300					6300
0	-18	7300	7300	7100	7400	7400	7500	6900					6900
5	-15	7700	7600	7500	7700	7700	7800	7200					7200
10	-12	8100	8000	7900	8100	8100	8200	7500					7500
15	-9	8300	8200	8100	8300	8400	8400	7700					7700
20	-7	8700	8600	8400	8700	8800	8900	8100					8100
25	-4	9600	9500	9300	9600	9700	9800	9000					9000
30	-1	10300	10200	10000	10300	10400	10500	9700					9700
35	2	11000	10900	10700	11100	11100	11200	10400					10400
40	4	11700	11600	11400	11800	11900	12000	11100					11100
45	7	12700	12600	12400	12800	12800	13000	11900					11900
50	10	13300	13100	12900	13300	13400	13500	12400					12400
55	13	13400	13300	13100	13500	13600	13700	12500					12500
60	16	13700	13600	13300	13700	13800	14000	12800					12800
65	18	14000	13800	13600	14000	14100	14300	13000					13000
70	21	14200	14100	13800	14200	14300	14500	13200					13200
75	24	14400	14300	14000	14400	14500	14700	13400					13400
78	26	14500	14400	14100	14600	14700	14800	13500					13500

TC = Total Capacity

Mechanical Specifications

Mini-Split Outdoor Unit

General

This unit is fully charged from the factory for up to 25 feet of piping. This unit is designed to operate at outdoor ambient temperatures as high as 115°F. Cooling capacities with the mini-split air handler shown in the catalog are AHRI certified. The unit is ETL listed for outdoor application.

Unit Casing

The unit casing is constructed of heavy gauge, galvanized steel and painted with a weather-resistant powder paint.

Refrigerant Controls

Refrigeration system controls include condenser fan and compressor relay. High and low pressure controls are inherent to the compressor. A suction line multi function service valve is standard

Compressor

The compressor features internal over temperature and pressure protection; total dipped hermetic motor windings. Other features include: centrifugal oil pump and low vibration and noise.

Condenser Coil

The coil shall consist of aluminum finned coils brazed to copper tubing. The coil provides air flow resistance and efficient heat transfer. The coil is protected by the casing.

Low Ambient Cooling

Matched Ameristar ductless products, have cooling capabilities at outdoor ambient temperatures as low as 0° F.

Mini-Split Indoor High Wall

General

The High Wall mounted type air handler shall be completely factory assembled including coil, condensate drain pan, fan motor, washable filter, air purifying filter and electric controls to be used with a wireless remote controller. Unit shall be shipped with a unit mounting plate. Unit shall be matched with an Ameristar outdoor unit, rated and tested in accordance with AHRI standard. Unit shall be ETL listed.

Unit Casing

Casing shall be provided with knockouts on the right, and left of the unit to facilitate piping and electrical connection on either side of the unit. An electrical service cover shall be provided to permit easy access to the electrical terminal strip.

Discharge Airflow and Distribution System

Unit shall have auto swing, dual horizontal blades to optimize the aperture outlet for vertical airflow and air distribution. Blade shall close automatically when the air conditioner is turned off to minimize dust entering the unit. Five-Step preset program on the remote controller shall be available to control the blade angle.

Manually adjusted wide-angle louvers shall be provided to adjust the coverage and direction of airflow.

Controls

Units shall have the capability to be controlled remotely through wall-mounted wired options as well as a wireless remote option.

Remote Controller

The unit shall have a wireless infrared remote controller with easy reading digital display panel to start, stop and regulate the air conditioner from a distance.

The wireless controller is available for all units. **(Sold separately)**

Healthy Filters

The unit shall have an active carbon and catechin filter with the unit. The filters need to be cleaned at least once a year.

